

Elysium
NOVELLINI ITALIAN DESIGN

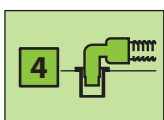

crystal 1
Istruzioni
Instructions
Instructions
Instrucciones

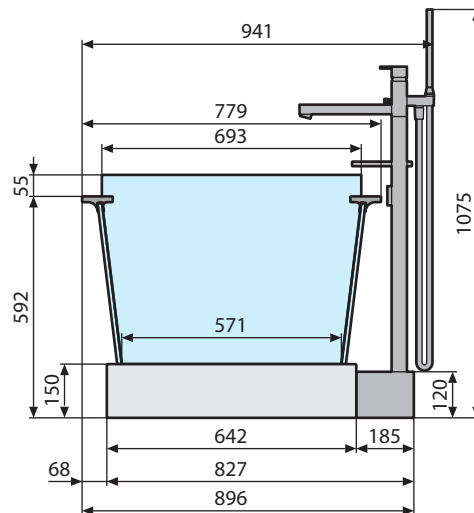
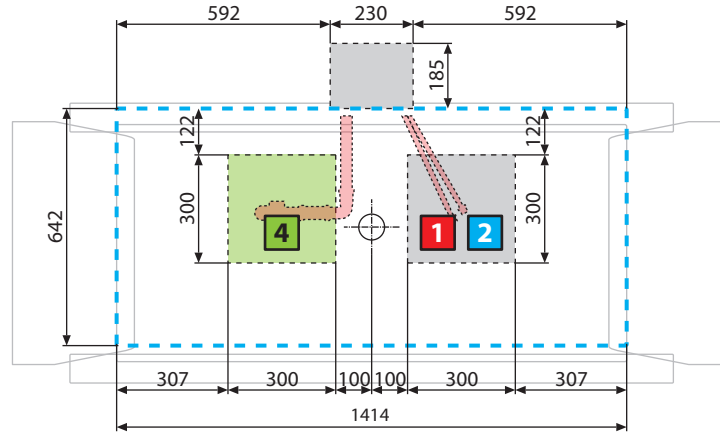
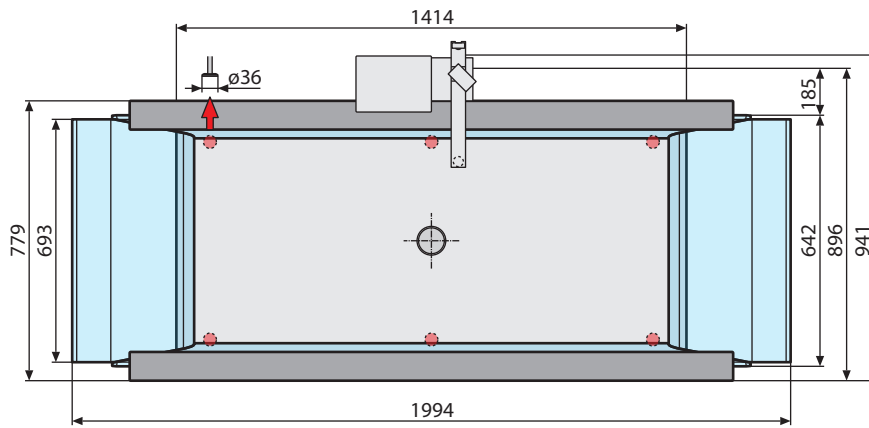
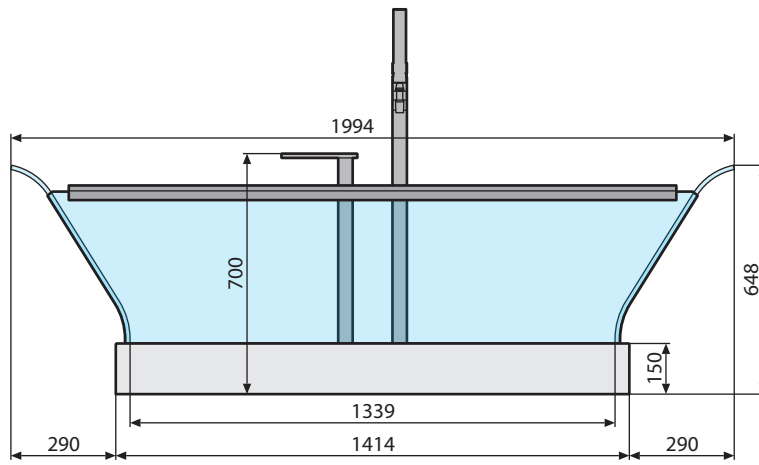

1

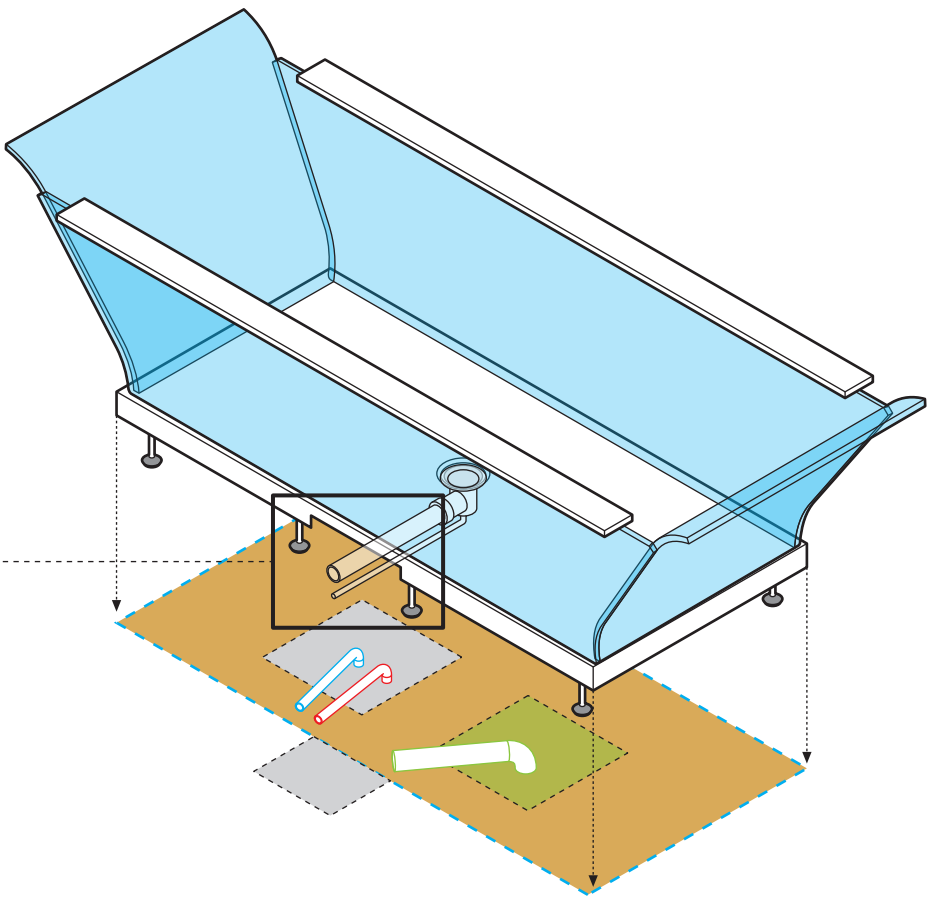
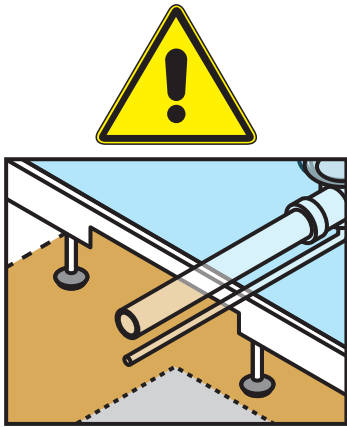

2

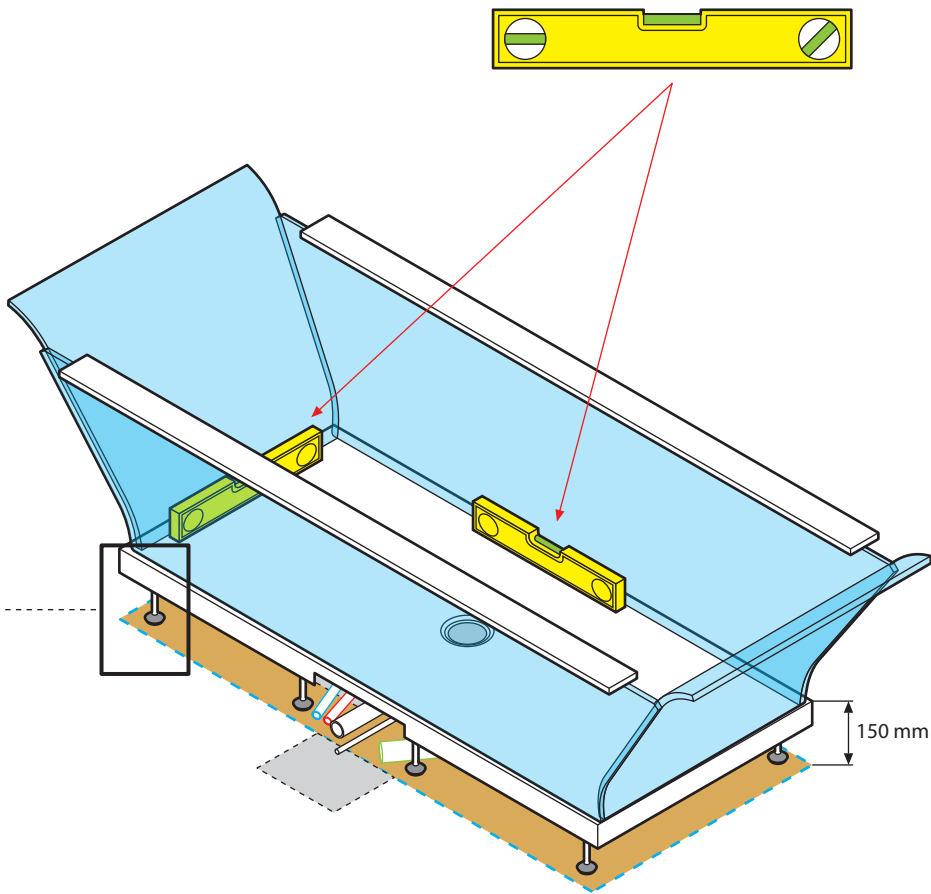
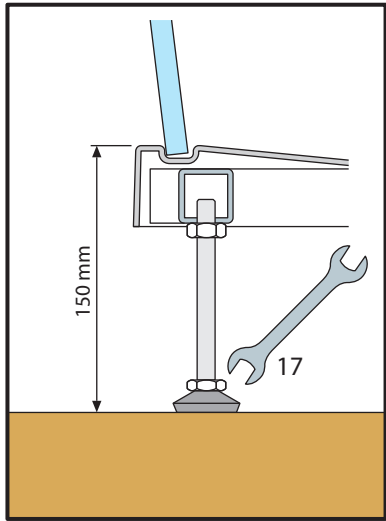

3

3

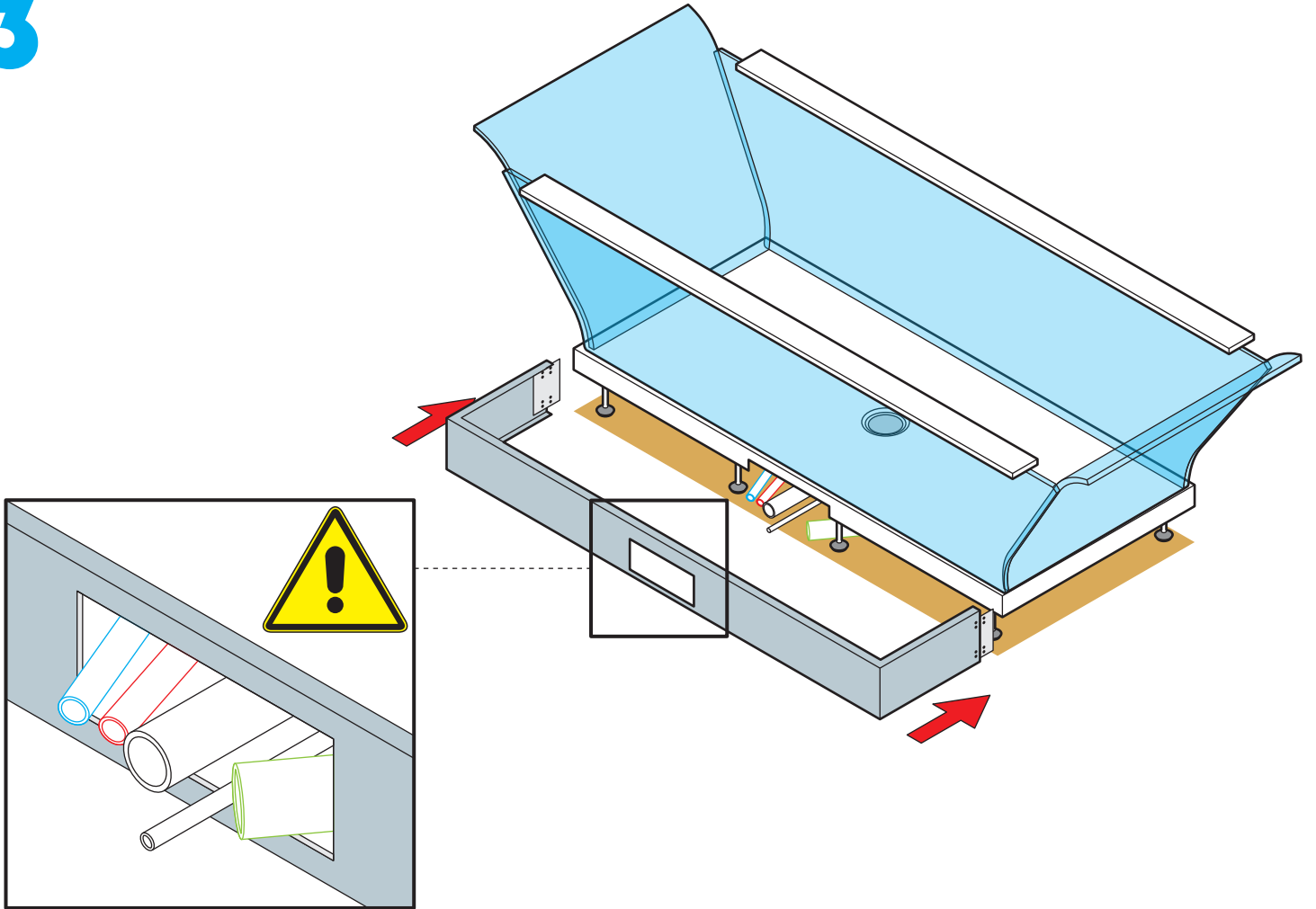

4

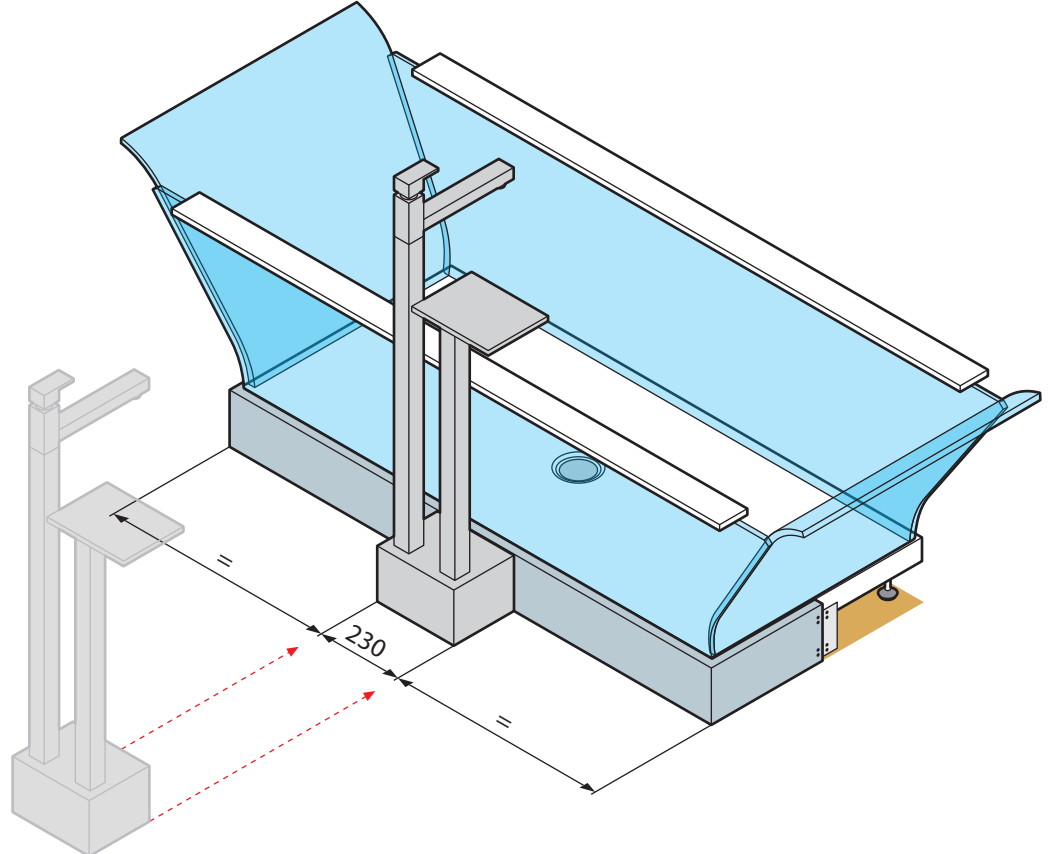

5

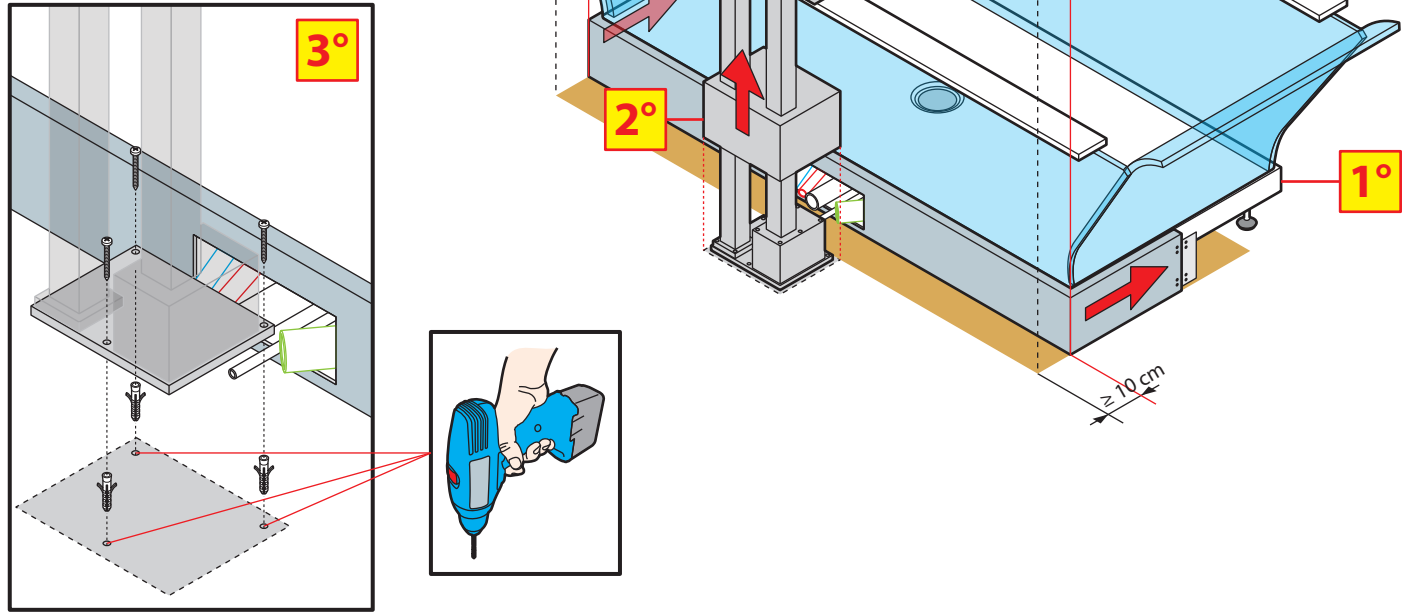

6

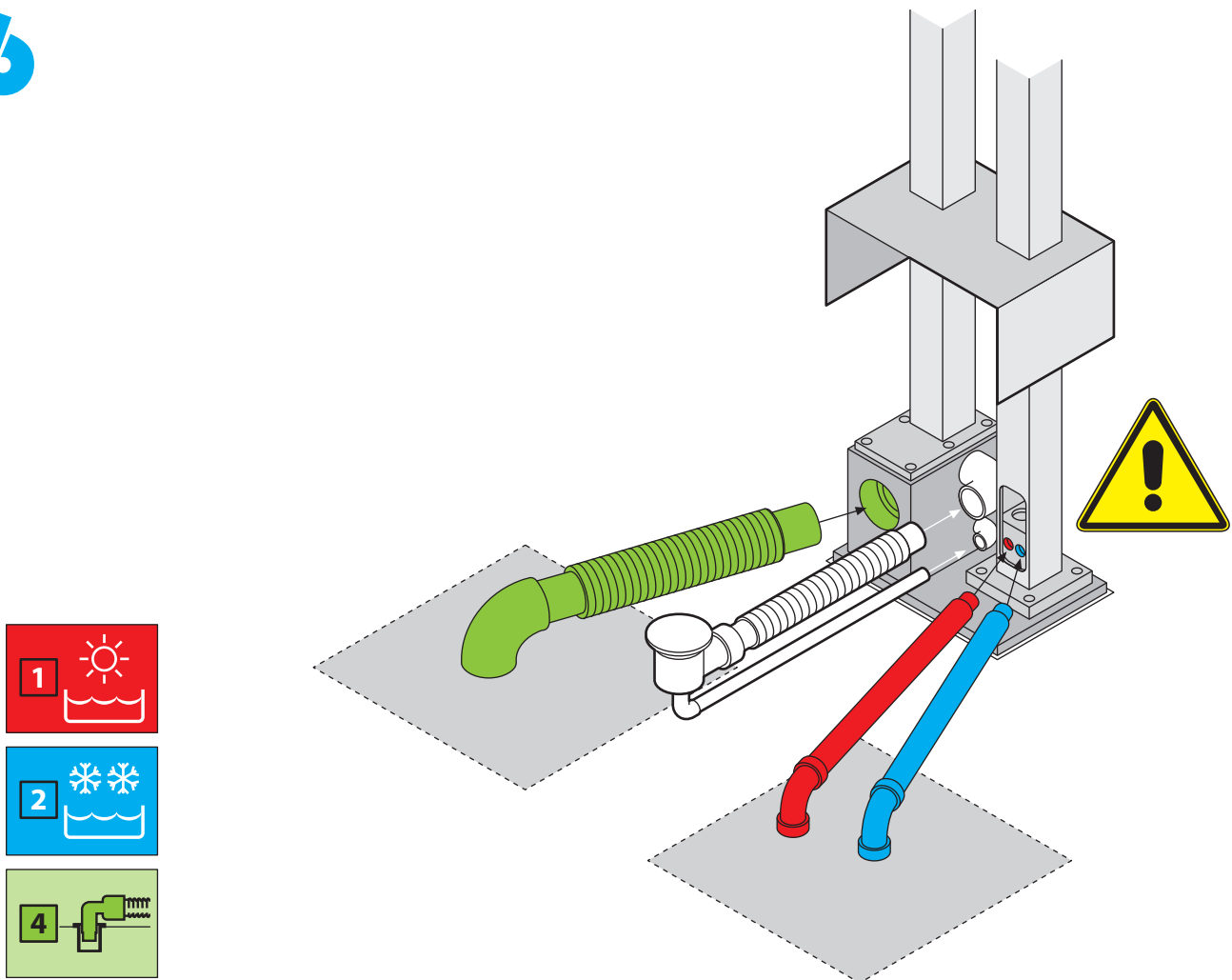

7

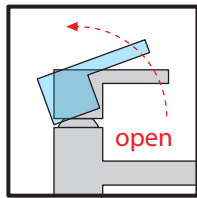

No!

1°

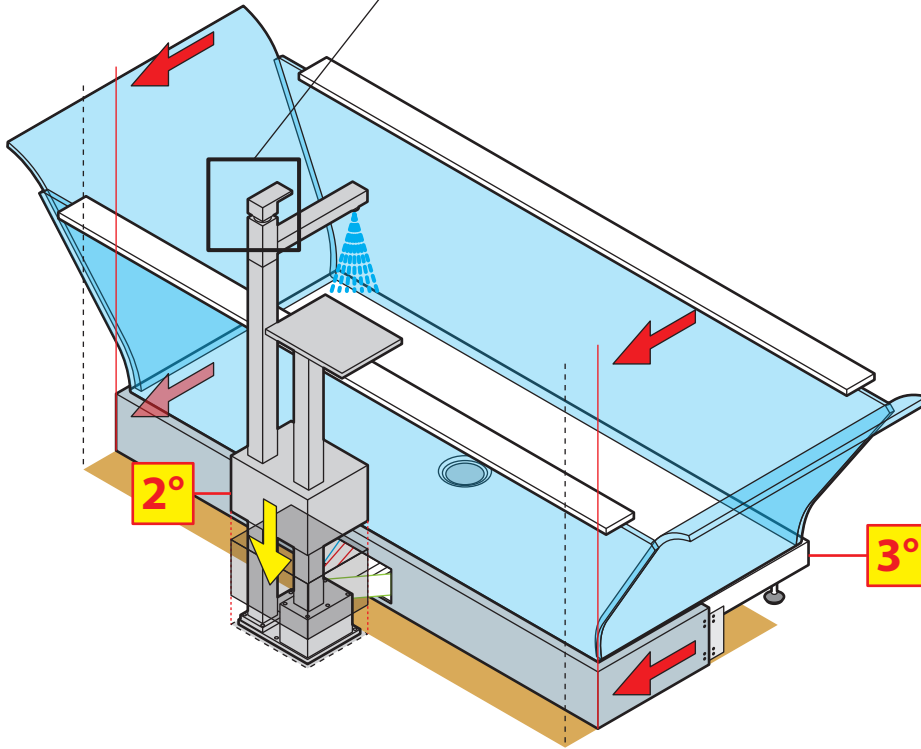
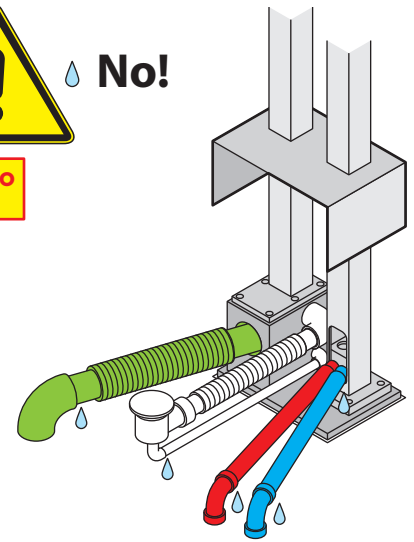

- IT Collaudo tenuta acqua
- FR Vérification de l'étanchéité
- EN Waterproof test
- DE Prüfung der Dichtheit
- NL Waterdichtheidstest
- ES Prueba de estanqueidad al agua
- CS Kontrola vodotěsnosti
- SL Pregled vodotesnosti
- HU Vízszivárgási próba
- PL Sprawdzenie wodozszczelności
- RU Испытание на герметичность
- PT Verificação da estanquidade à água

8

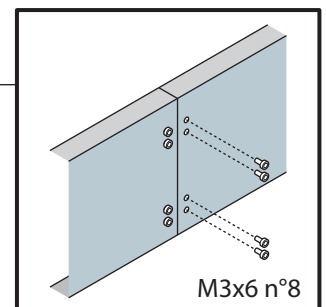
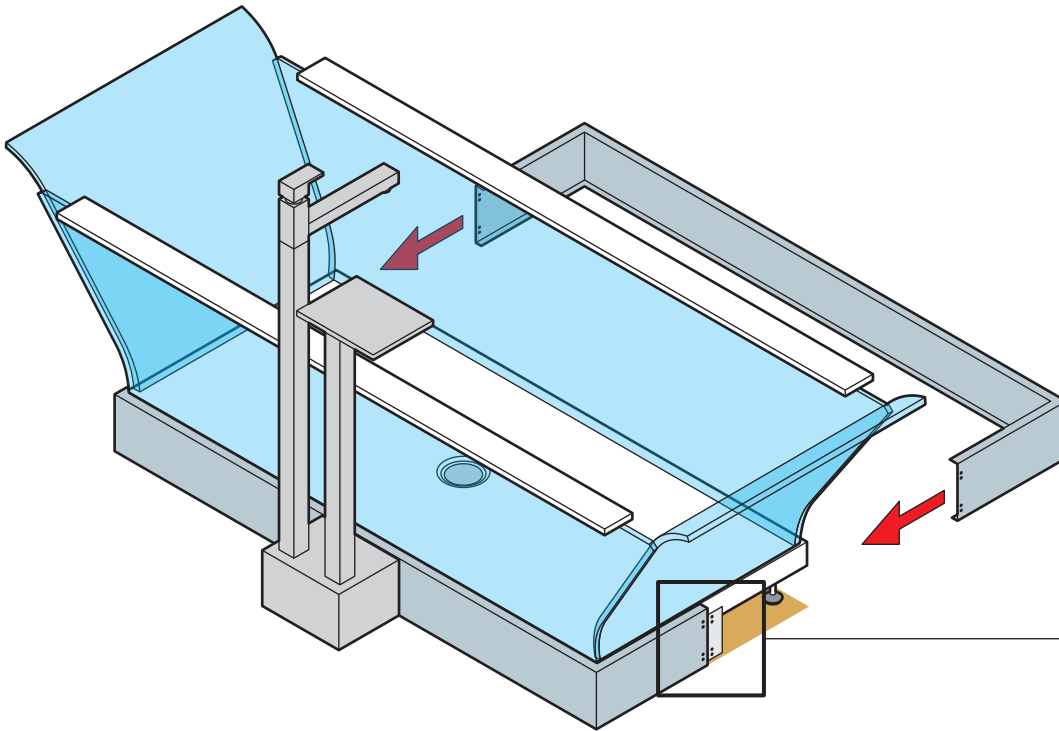

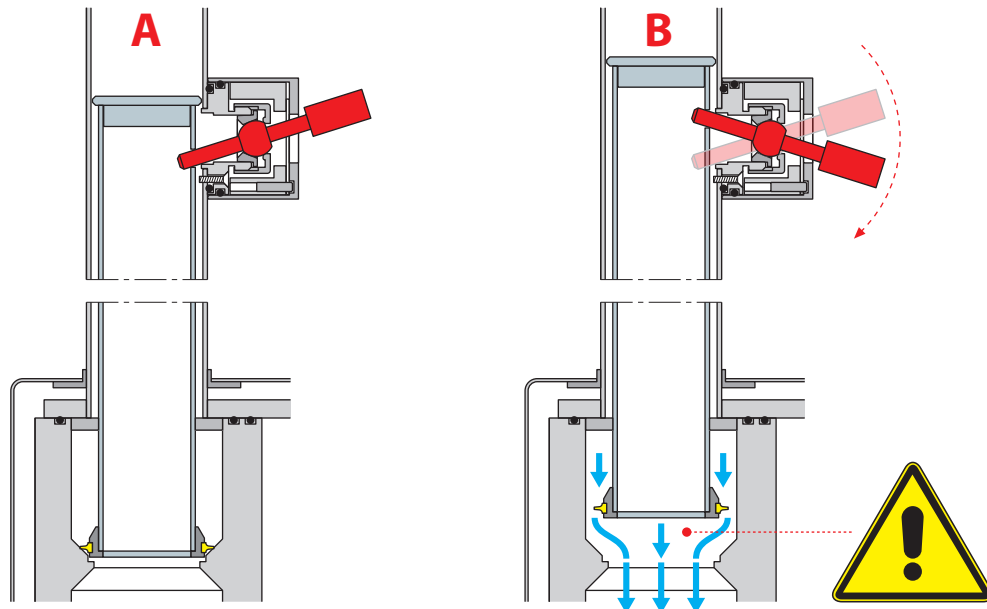

IT ATTENZIONE:
IL RIEMPIMENTO DELLA VASCA DEVE AVVENIRE CON ACQUA TIEPIDA: LA TEMPERATURA PUO' GRADUALMENTE ESSERE INCREMENTATA SENZA MAI SUPERARE I 65°C PER EVITARE INCRINATURE E ROTTURE.

FR ATTENTION!
LE BAC DOIT ÊTRE REMPLI AVEC DE L'EAU TIÈDE: LA TEMPÉRATURE PEUT ÊTRE AUGMENTÉE GRADUELLEMENT SANS JAMAIS DÉPASSER 65°C AFIN D'ÉVITER TOUTE FISSURE ET TOUTE RUPTURE.

EN IMPORTANT:
THE BATH MUST BE FILLED WITH LUKEWARM WATER: THE TEMPERATURE CAN BE GRADUALLY INCREASED, BUT MUST NEVER EXCEED 65°C TO AVOID CRACKS AND BREAKAGE.

DE ACHTUNG:
DIE WANNE MUSS MIT LAUWARMEM WASSER GEFÜLLT WERDEN: DIE TEMPERATUR KANN ALLMÄHLICH ERHÖHT WERDEN. DABEI DÜRFEN 65 °C NICHT ÜBERSCHRITTEN WERDEN, UM RISSE UND BESCHÄDIGUNGEN ZU VERMEIDEN.

NL LET OP:
HET BAD MOET WORDEN GEVULD MET LAUW WATER: DE TEMPERATUUR KAN GELEIDELIJK WORDEN VERHOOGD, ZONDER DE 65°C TE OVERSCHRIJDEN, OM BARSTEN EN BREUK TE VERMIJDEN.

ES ATENCIÓN:
LA BAÑERA SE DEBE LLENAR CON AGUA TIBIA: LA TEMPERATURA SE PUEDE AUMENTAR GRADUALMENTE, SIN SUPERAR NUNCA 65 °C PARA EVITAR LA FORMACIÓN DE GRIETAS Y RUPTURAS.

CS UPOZORNĚNÍ:
VANA MUSÍ BÝT NAPLNĚNA VLAŽNOU VODOU: TEPLOTA MŮŽE BÝT POSTUPNĚ ZVYŠOVÁNA, ALE NESMÍ NIKDY PŘESÁHNOUT 65°C, ABY NEDOŠLO K PRASKLINÁM A POŠKOZENÍ.

SL POZOR:
KAD MORA BITI POLNJENA Z MLAČNO VODO: TEMPERATURO JE MOŽNO POSTOPOMA POVIŠEVATI, VENDAR NI DOVOLJENO PREKORACITI 65°C, DA SE PREPREČI RAZPOKANJE IN POŠKODBE.

HU FIGYELEM!
A KÁDAT LANGYOS VÍZZEL KELL FELTÖLTENI: A HŐMÉRSÉKLETET FOKOZATOSAN LEHET EMELNI, DE A REPEDÉSEK ÉS TÖRÉSEK ELKERÜLÉSE ÉRDEKÉBEN SOSEM SZABAD TÚLLÉPNI A 65°C-OT.

PL UWAGA!
WANNA WINNA BYĆ NAPEŁNIONA LETNIĄ WODĄ: TEMPERATURĘ MOŻNA ZWYŻYĆ POSTĘPNIE, NIE PRZEKRACZAJĄC JEDNAK 65°C, BY UNIKNĄĆ PĘKNIĘĆ I ZŁAMAŃ.

RU ВНИМАНИЕ!
ВАННУ СЛЕДУЕТ НАПОЛНИТЬ ТЕПЛОЙ ВОДОЙ: ТЕМПЕРАТУРУ МОЖНО ПОВЫСИТЬ ПОСТЕПЕННО, НО НИКОГДА НЕ ПРЕВЫШАЯ 65°C, ЧТОБЫ НЕ ВЫЗВАТЬ ТРЕЩИН И ПОЛОМКИ.

PT ATENÇÃO!
O ENCHIMENTO DA BANHEIRA DEVE SER FEITO COM ÁGUA MORNIA: A TEMPERATURA PODE SER AUMENTADA GRADUALMENTE, MAS SEM NUNCA ULTRAPASSAR 65°C, PARA EVITAR FISSURAÇÃO E DANOS.

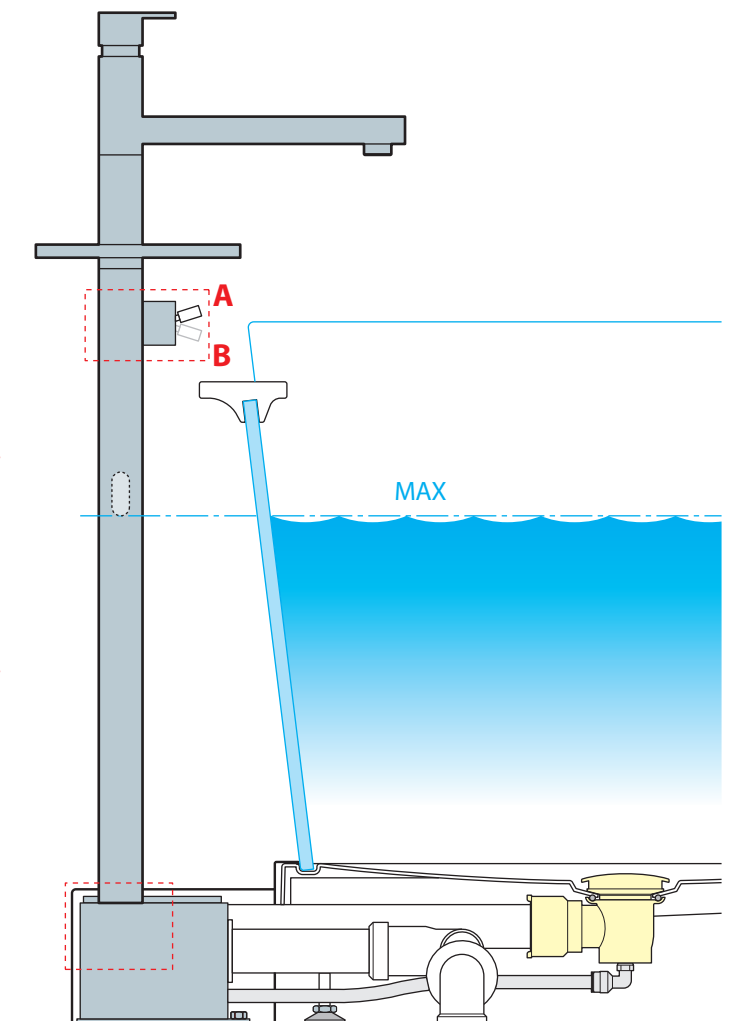



Novellini
DESIGN

NOVELLINI S.p.A.

Via della Stazione, 2 - 46030 Romanore di - Borgoforte (Mn)

Tel. +39 0376 6421 - Fax +39 0376 642250 - e-mail: novellini@novellini.it

www.novellini.com

60485IST_02 (03 2010)